

SECTION T

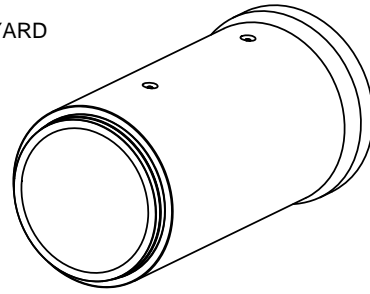

ISOMETRIC VIEW

ENGINEER STAMP (IF REQUIRED)

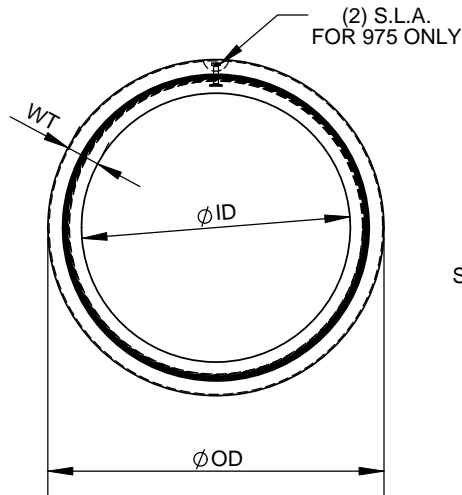

FRONT VIEW

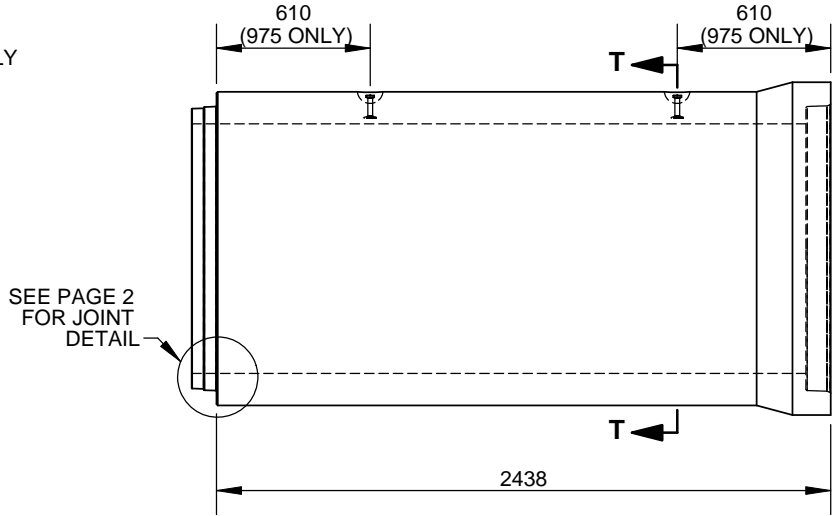

SIDE VIEW

PRODUCT VARIABLES

PART ID	NOMINAL SIZE	ID	OD	WT	MASS (KG)	CLASS AVAILABILITY			MFG	SLA	
						65D	100D	140D		SPEC.	PART ID
PA0300X4	300	305	445	69.9	550	S	S	Y	OAK	--	--
PA0375X4	375	381	533	76.2	746	S	S	Y	OAK	--	--
PA0450X4	450	457	622	82.6	930	S	S	Y	OAK	--	--
PA0525X4	525	533	711	88.9	1140	S	S	Y	OAK	--	--
PA0600X4	600	610	800	95.3	1410	S	Y	Y	OAK	--	--
PA0675X4	675	686	889	101.6	1680	S	Y	Y	OAK	--	--
PA0750X4	750	762	978	108.0	1905	S	Y	Y	OAK	--	--
PA0825X4	825	838	1067	114.3	2225	S	Y	Y	OAK	--	--
PA0900X4	900	914	1156	120.7	2535	S	Y	Y	OAK	--	--
PA0975X4	975	991	1245	127.0	2915	Y	Y	Y	GUE	4T 3-1/2	RLA140090
									OAK	4T 3-1/2 DH	RLA040090

* CLASS AVAILABILITY - S: SUBSTITUED BY NEXT AVAILABLE CLASS

ALL DIMENSIONS ARE IN mm
DRAWINGS ARE NOT TO SCALE
REFER TO PIPE STEEL DESIGN FOR
REINFORCING DETAILS

MIN. CONC STRENGTH 30-40 MPa
BASE ON CLASS
CLEAR COVER DEPENDS ON CAGE
DESIGN. REF TO CSA 257.2
TOLERANCES TO CSA A23.4-09

ONTARIO CONCRETE PRODUCTS (OCP) STANDARD DRAWING

STD: CSA 257.2 REV OCT 2009 PART PA0XXXX4

TITLE
REINFORCED CONCRETE PIPE
300 - 975mm DIAMETER

2	CORRECT OD VARIABLE	CW	17/OCT/11
1	NEW SOLIDWORKS DWG	SW	4/JAN/11
REV.	DESCRIPTION	ENG.	DATE

DRAWN BY SW	CHECKED BY	DATE 4/JAN/11	FILE Pipe	PAGE 1 OF 2
----------------	------------	------------------	--------------	----------------

STENCIL (S1)
(SIZE) X (CLASS)

STENCIL (S2)
OCP-OAKVILLE
CSA A257.2
(SIZE) X (CLASS)
TYPE 50
DATE OF MFG

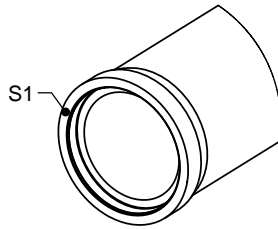

ISOMETRIC
BELL END VIEW

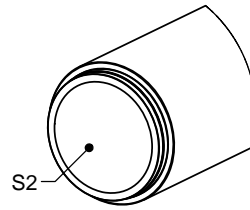

ISOMETRIC
SPIGOT END VIEW

ENGINEER STAMP (IF REQUIRED)

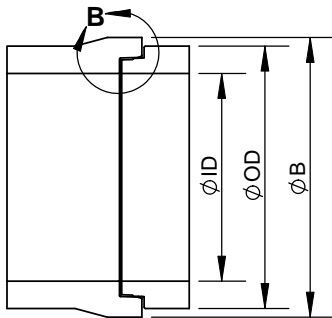

PIPE JOINT
SECTION VIEW

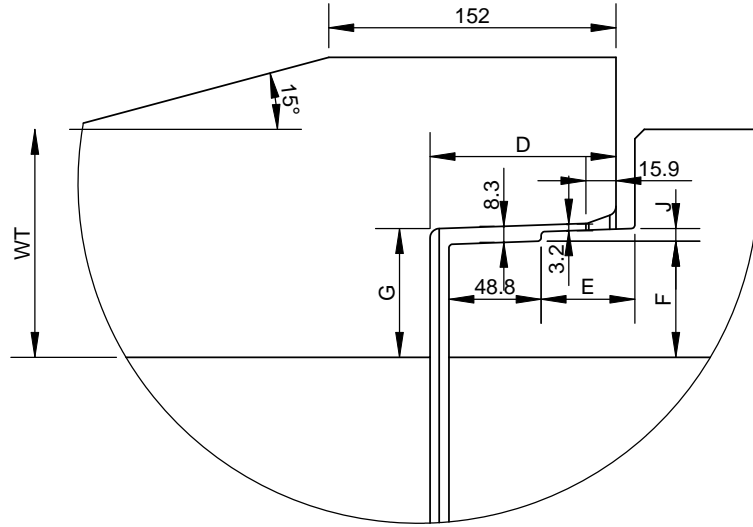

DETAIL B

PART ID	NOMINAL SIZE	ID	OD	WT	B	D	E	F	G	J
PA0300X4	300	305	445	69.9	508	90.5	41.7	34.7	41.3	5.1
PA0375X4	375	381	533	76.2	609	90.5	41.7	40.9	47.6	6.4
PA0450X4	450	457	622	82.6	705	95.3	46.4	48.9	55.6	6.6
PA0525X4	525	533	711	88.9	806	95.3	46.4	55.2	61.9	6.6
PA0600X4	600	610	800	95.3	908	98.4	49.6	61.6	68.4	6.7
PA0675X4	675	686	889	101.6	1009	98.4	49.6	67.6	74.3	6.7
PA0750X4	750	762	978	108.0	1041	98.4	49.6	55.1	61.8	6.7
PA0825X4	825	838	1067	114.3	1143	98.4	49.6	61.5	68.2	6.7
PA0900X4	900	914	1156	120.7	1232	98.4	49.6	61.5	68.2	6.7
PA0975X4	975	991	1245	127.0	1321	98.4	49.6	61.5	68.2	6.7

ALL DIMENSIONS ARE IN mm
DRAWINGS ARE NOT TO SCALE

MIN. CONC STRENGTH 30-40 MPa
BASE ON CLASS
CLEAR COVER DEPENDS ON CAGE
DESIGN. REF TO CSA 257.2
TOLERANCES TO CSA A23.4-09

ONTARIO CONCRETE PRODUCTS (OCP) STANDARD DRAWING

STD: CSA 257.2 REV OCT 2009 PART PA0XXXX4

TITLE
REINFORCED CONCRETE PIPE
300 - 975mm DIAMETER
JOINT AND STENCILING DETAILS

2	ADD ENG STAMP	CW	19/OCT/11
1	NEW SOLIDWORKS DWG	SW	4/JAN/11
REV.	DESCRIPTION	ENG.	DATE

DRAWN BY SW	CHECKED BY CW	DATE 4/JAN/11	FILE Pipe	PAGE 2 OF 2
----------------	------------------	------------------	--------------	----------------