

ADD. STENCIL
 BEND
 (LEFT/RIGHT)
 (B)

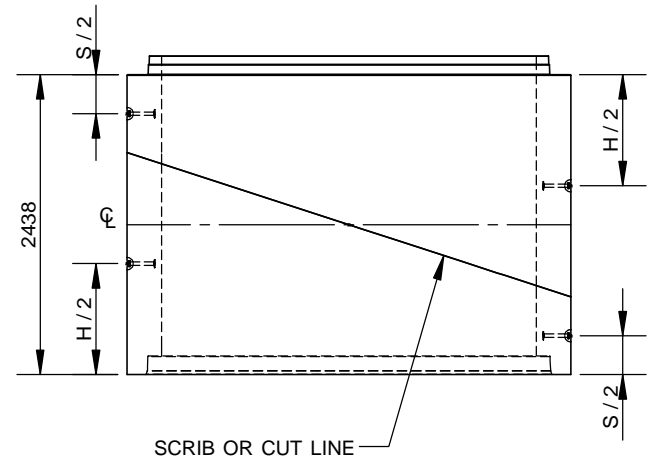
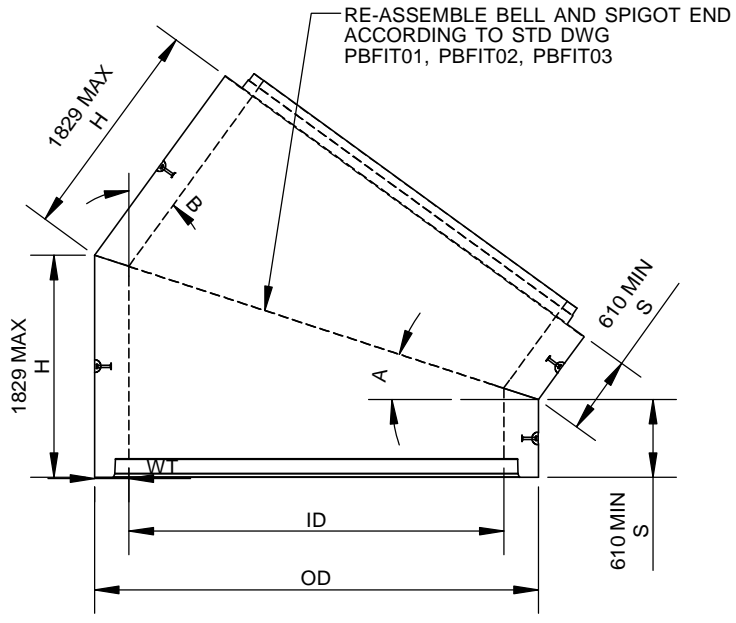
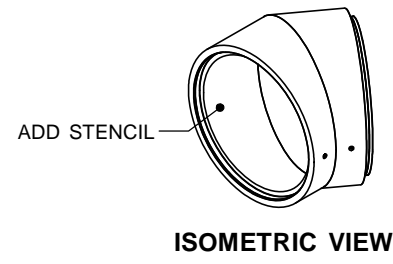

MAXIMUM BEND ANGLE					
PART ID	ID	OD	WT	A (°)	B (°)
PB1050X4	1067	1334	133	42	84
PB1200X48	1219	1473	127 BW	40	80
PB1200X49	1219	1511	146 CW	39	78
PB1350X48	1372	1652	140 BW	36	72
PB1350X49	1372	1689	159 CW	36	72
PB1500X4	1524	1829	152	33	66
PB1650X4	1676	2007	165	31	62
PB1800X4	1829	2184	178	29	58
PB1950X4	1981	2362	191	27	54
PB2100X4	2134	2540	203	25	50
PB2250X4	2134	2718	216	24	48
PB2400X4	2286	2896	229	23	46
PB2550X4	2591	3073	241	21	42
PB2700X4	2743	3251	254	20	40
PB3000X4	3048	3607	279	18	36

ENGINEER STAMP (IF REQUIRED)

ALL DIMENSIONS ARE IN mm
 DRAWINGS ARE NOT TO SCALE
 REFER TO STD DWG PAXXXXX4 FOR
 PIPE GEOMETRY AND SLA SIZE

CON CAST PIPE (CCP) STANDARD DRAWING

STD. PART PB02

TITLE
**REINFORCED CONCRETE PIPE BEND
 1050 - 3000 mm DIAMETER
 MAXIMUM BEND ANGLE AND SLA PLACEMENT**

0	INITIAL RELEASE	SW	12JUN12	DRAWN BY	CHECKED BY	DATE	FILE	PAGE
REV.	DESCRIPTION	ENG.	DATE	SW	AP	4JUN12	Pipe Bend	1 OF 1

G:\Engineering\Library\Solidworks\Pipe\Pipe Bend\