

NOTES:

1. S.L.A. ON SINGLE OR DOUBLE CAGE DESIGN TO BE LOCATED ANYWHERE ON THE CIRCUMFERENCE
2. ENSURE S.L.A. RECESSES ARE FREE DRAINING WHEN STORE IN THE YARD

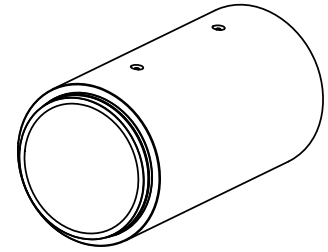

ISOMETRIC VIEW

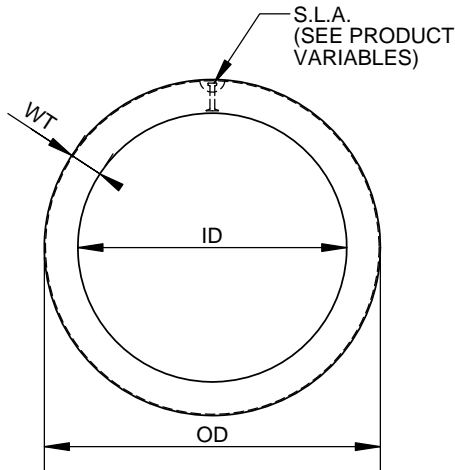

TYPICAL SECTION

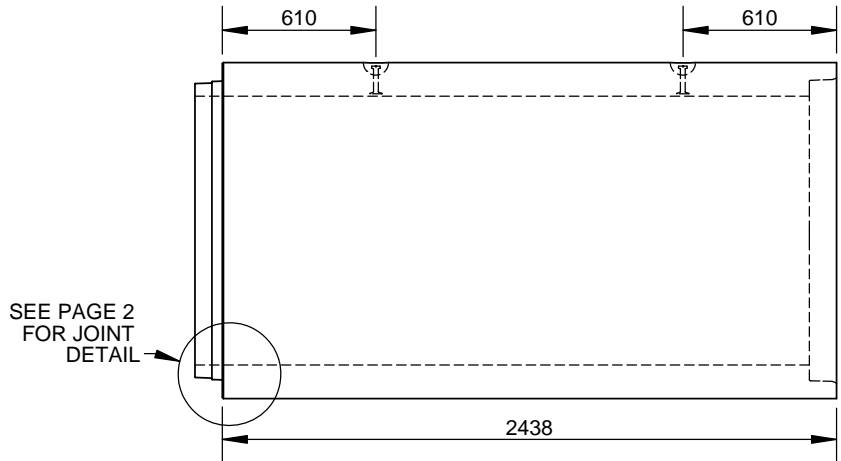

SIDE VIEW

PRODUCT VARIABLES

PART ID	NOMINAL SIZE	ID	OD	WT	MASS (KG)	MFG	SLA		MIN. SLING ANGLE
							SPEC.	f'c (MPa)	
PA1050X4	1050	1067	1334	133	3115	GUE	4T 3-1/2	30	60
						OAK	4T 3-1/2 DH	30	60
PA1200X48	1200	1219	1473	127 BW	3475	OAK	4T 3-1/2 DH	30	60
PA1200X49	1200	1219	1511	146 CW	3810	GUE	4T 4-1/4	30	60
PA1350X48	1350	1372	1652	140 BW	4115	OAK	4T 4-1/4 DH	30	60
PA1350X49	1350	1372	1689	159 CW	4731	GUE	4T 4-3/4	30	60
						OAK	4T 4-1/4 DH	30	60
PA1500X4	1500	1524	1829	152	5180	GUE	4T 4-3/4	35	60
						OAK	4T 4-1/4 DH	30	60
PA1650X4	1650	1676	2007	165	6101	GUE	4T 4-3/4	40	60
PA1800X4	1800	1829	2184	178	6991	GUE	8T 5-3/4	30	60
PA1950X4	1950	1981	2362	191	8110	GUE	8T 5-3/4	40	60
PA2100X4	2100	2134	2540	203	9290	GUE	8T 6-1/4	30	60
PA2250X4	2250	2286	2718	216	10520	GUE	8T 6-3/4	30	60
PA2400X4	2400	2438	2896	229	11880	GUE	8T 7-1/8	30	60
PA2550X4	2550	2591	3073	241	12637	GUE	8T 7-1/8	40	60
PA2700X4	2700	2743	3251	254	14035	GUE	8T 8-1/4	40	60
PA3000X4	3000	3048	3607	279	17185	GUE	20T 10	40	60

ALL DIMENSIONS ARE IN mm
DRAWINGS ARE NOT TO SCALE
VIEWS ARE AS INSTALLED
STANDARD CLASS: 65D, 100D, 140D
LIFTING RIGGING CODE: S2S-SP
REF TO REG DWG: LH-PA02

MIN. CONC STRENGTH 30-40 MPa
BASED ON CLASS
CLEAR COVER DEPENDS ON CAGE
DESIGN. REF TO CSA 257.2-14
TOLERANCES TO CSA A257.2-14

CON CAST PIPE (CCP) STANDARD DRAWING

STD. CSA 257.2 REV 2014 DOC PAXXXX4

**REINFORCED CONCRETE PIPE
1050 - 3000 mm DIAMETER
SIZE GUIDE**

8	SLA UPDATE, RIGGING REF, CSA A257.2 UPDATE	RM	5APR16
7	SLA UPDATE FOR 2550	RM	7/NOV/14
6	REVIEWED, SLA NOTES	SW	17/SEP/14
REV.	DESCRIPTION	ENG.	DATE

DRAWN BY SW	CHECKED BY CW	DATE 4/JAN/11	FILE Pipe	PAGE 1 OF 2
----------------	------------------	------------------	--------------	----------------

STENCIL (S1)
(SIZE) X (CLASS)
STENCIL (S2)
(CCP-GUELPH / OCP-OAKVILLE)
CSA A257.2
(SIZE) X (CLASS)
TYPE HSe
(DATE OF MFG)

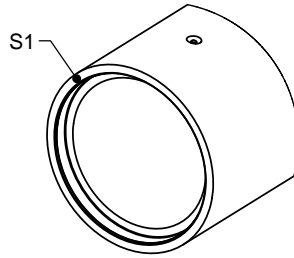

**ISOMETRIC
BELL END VIEW**

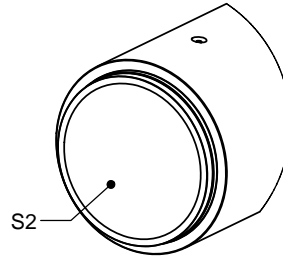

**ISOMETRIC
SPIGOT END VIEW**

ENGINEER STAMP (IF REQUIRED)

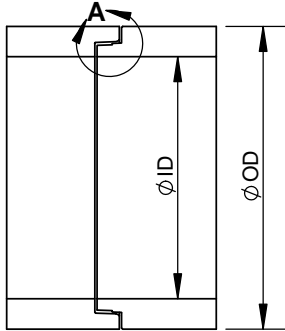

**PIPE JOINT
SECTION VIEW**

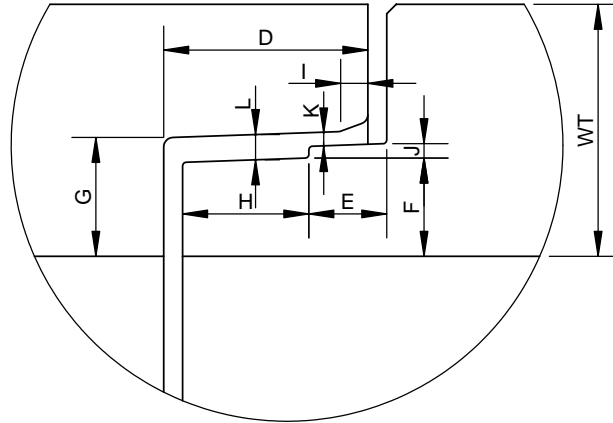

DETAIL A

PART ID	NOMINAL SIZE	ID	OD	WT	D	E	F	G	H	I	J	K	L
PA1050X4	1050	1067	1334	133	108.0	41.2	53.0	62.1	66.8	15.9	7.6	3.7	11.3
PA1200X48	1200	1219	1473	127 BW	108.0	44.5	53.0	62.1	63.5	19.1	7.6	3.7	11.3
PA1200X49	1200	1219	1511	146 CW	108.0	41.2	52.2	62.1	66.8	15.9	7.6	3.7	11.3
PA1350X48	1350	1372	1652	140 BW	108.0	44.5	49.3	58.4	63.5	22.2	7.6	3.7	11.3
PA1350X49	1350	1372	1689	159 CW	108.0	41.2	49.5	58.4	66.8	15.9	7.6	3.7	11.3
PA1500X4	1500	1524	1829	152	120.7	53.9	55.8	64.7	66.8	22.2	7.6	3.7	11.3
PA1650X4	1650	1676	2007	165	127.0	60.2	62.2	71.1	66.8	22.2	7.6	3.7	11.3
PA1800X4	1800	1829	2184	178	127.0	60.2	65.7	74.6	66.8	31.8	7.6	3.7	11.3
PA1950X4	1950	1981	2362	191	127.0	57.1	71.4	82.2	69.9	31.8	8.9	4.4	13.3
PA2100X4	2100	2134	2540	203	127.0	57.1	77.7	88.5	69.9	31.8	8.9	4.4	13.3
PA2250X4	2250	2286	2718	216	127.0	57.1	84.1	94.9	69.9	31.8	8.9	4.4	13.3
PA2400X4	2400	2438	2896	229	127.0	57.1	90.4	101.2	69.9	31.8	8.9	4.4	13.3
PA2550X4	2550	2591	3073	241	127.0	57.1	96.4	107.5	69.9	31.8	8.9	4.4	13.3
PA2700X4	2700	2743	3251	254	127.0	57.1	103.1	114.0	69.9	31.8	8.9	4.4	13.3
PA3000X4	3000	3048	3607	279	152.0	82.1	99.9	110.8	69.9	31.8	8.9	4.4	13.3

ALL DIMENSIONS ARE IN mm
DRAWINGS ARE NOT TO SCALE

MIN. CONC STRENGTH 30-40 MPa
BASED ON CLASS
CLEAR COVER DEPENDS ON CAGE
DESIGN. REF TO CSA 257.2
TOLERANCES TO CSA A257.2

CON CAST PIPE (CCP) STANDARD DRAWING

STD: CSA 257.2 REV 2014 DOC: PAXXXXX4

TITLE: **REINFORCED CONCRETE PIPE
1050 - 3000 mm DIAMETER
JOINT AND STENCILING DETAILS**

4	CSA A257.2-14	SW	5APR2016
3	CORRECT ERROR F AND G VALUES	SW	12/JUN/12
2	ADD ENG. STAMP	CW	19/OCT/11
REV.	DESCRIPTION	ENG.	DATE

DRAWN BY SW	CHECKED BY CW	DATE 4/JAN/11	FILE Pipe	PAGE 2 OF 2
----------------	------------------	------------------	--------------	----------------