

NOTES:

1. NO S.L.A. IS REQUIRED FOR SIZE LESS THAN 975
2. FOR 975, ENSURE S.L.A. RECESSES ARE FREE DRAINING WHEN STORE IN THE YARD

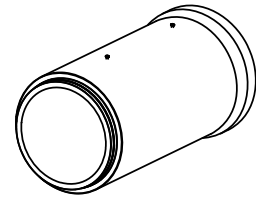

ISOMETRIC VIEW

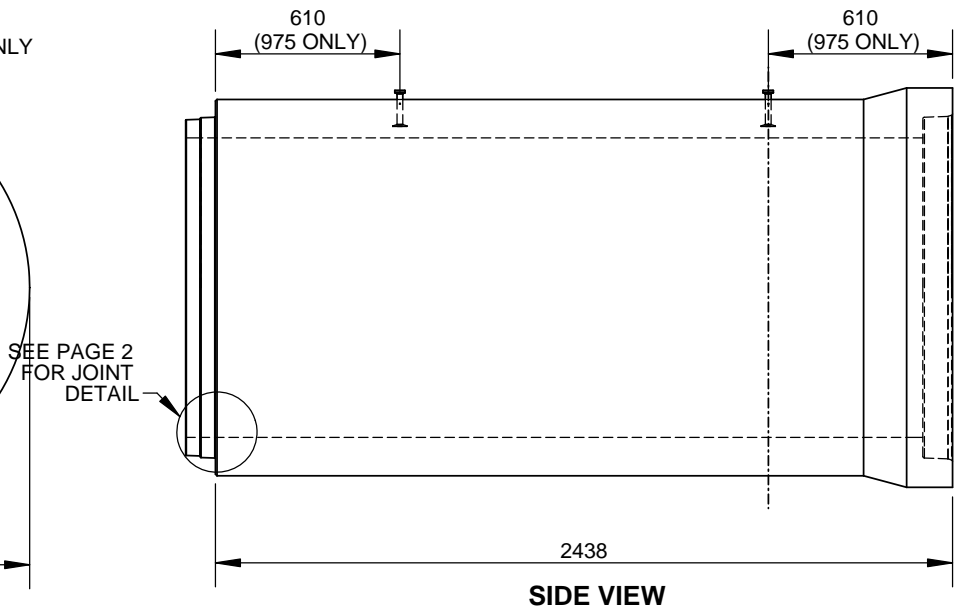
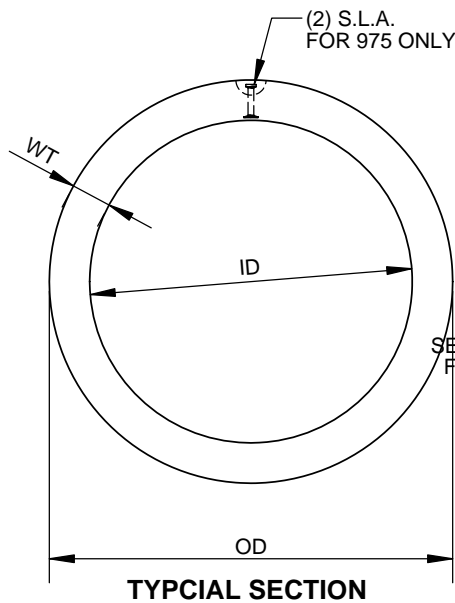

PRODUCT VARIABLES										
PART ID	NOMINAL SIZE	ID	OD	WT	MASS (KG)	CLASS AVAILABILITY			MFG	SLA
						65D	100D	140D		SPEC.
PA0300X4	300	305	445	69.9	550	S	S	Y	OAK	--
PA0375X4	375	381	533	76.2	746	S	S	Y	OAK	--
PA0450X4	450	457	622	82.6	930	S	S	Y	OAK	--
PA0525X4	525	533	711	88.9	1140	S	S	Y	OAK	--
PA0600X4	600	610	800	95.3	1410	S	Y	Y	OAK	--
PA0675X4	675	686	889	101.6	1680	S	Y	Y	OAK	--
PA0750X4	750	762	978	108.0	1905	S	Y	Y	OAK	--
PA0825X4	825	838	1067	114.3	2225	S	Y	Y	OAK	--
PA0900X4	900	914	1156	120.7	2535	S	Y	Y	OAK	--
PA0975X4	975	991	1245	127.0	2915	Y	Y	Y	GUE	4T 3-1/2
									OAK	4T 3-1/2 DH

* CLASS AVAILABILITY - S: SUBSTITUED BY NEXT AVAILABLE CLASS

ALL DIMENSIONS ARE IN mm
DRAWINGS ARE NOT TO SCALE
VIEWS ARE AS INSTALLED

MIN. CONC STRENGTH 30-40 MPa
BASED ON CLASS
CLEAR COVER DEPENDS ON CAGE
DESIGN. REF TO CSA 257.2-14
TOLERANCES TO CSA A257.2-14

CON CAST PIPE (CCP) STANDARD DRAWING

STD: CSA A257.2 REV 2014 DOC: PA0XXXX4

TITLE: **REINFORCED CONCRETE PIPE
300 - 975 mm DIAMETER
SIZE GUIDE**

4	CSA A257.2-2014	SW	5APR16
3	TITLE BLOCK TO CCP, NOTES, STENCILING	SW	16SEP14
2	CORRECT OD VARIABLE	CW	17OCT11
REV.	DESCRIPTION	ENG.	DATE

DRAWN BY SW	CHECKED BY	DATE 4JAN11	FILE Pipe	PAGE 1 OF 2
----------------	------------	----------------	--------------	----------------

STENCIL (S1)
(SIZE) X (CLASS)

STENCIL (S2)
OCP-OAKVILLE
CSA A257.2
(SIZE) X (CLASS)
TYPE HSe
(DATE OF MFG)

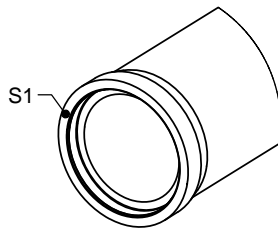

ISOMETRIC
BELL END VIEW

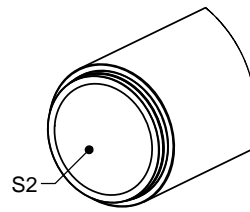

ISOMETRIC
SPIGOT END VIEW

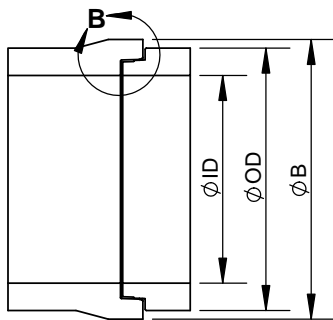

PIPE JOINT
SECTION VIEW

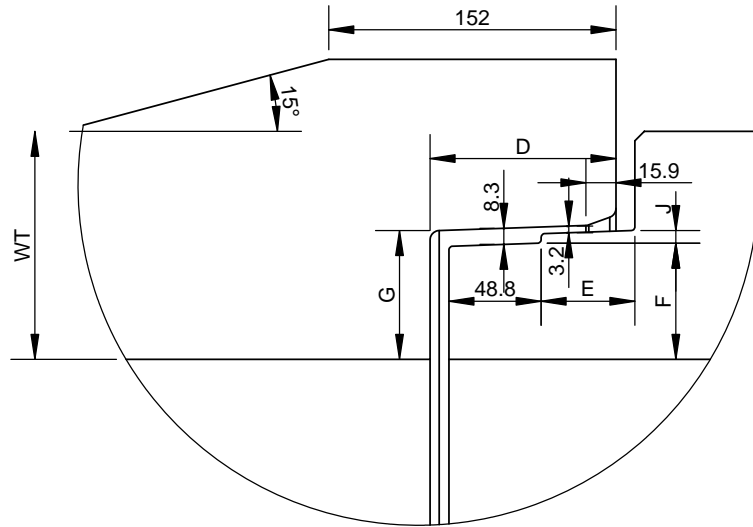

DETAIL B

PART ID	NOMINAL SIZE	ID	OD	WT	B	D	E	F	G	J
PA0300X4	300	305	445	69.9	508	90.5	41.7	34.7	41.3	5.1
PA0375X4	375	381	533	76.2	609	90.5	41.7	40.9	47.6	6.4
PA0450X4	450	457	622	82.6	705	95.3	46.4	48.9	55.6	6.6
PA0525X4	525	533	711	88.9	806	95.3	46.4	55.2	61.9	6.6
PA0600X4	600	610	800	95.3	908	98.4	49.6	61.6	68.4	6.7
PA0675X4	675	686	889	101.6	1009	98.4	49.6	67.6	74.3	6.7
PA0750X4	750	762	978	108.0	1041	98.4	49.6	55.1	61.8	6.7
PA0825X4	825	838	1067	114.3	1143	98.4	49.6	61.5	68.2	6.7
PA0900X4	900	914	1156	120.7	1232	98.4	49.6	61.5	68.2	6.7
PA0975X4	975	991	1245	127.0	1321	98.4	49.6	61.5	68.2	6.7

ALL DIMENSIONS ARE IN mm
DRAWINGS ARE NOT TO SCALE

MIN. CONC STRENGTH 30-40 MPa
BASE ON CLASS
CLEAR COVER DEPENDS ON CAGE
DESIGN. REF TO CSA 257.2
TOLERANCES TO CSA A257.2

CON CAST PIPE (CCP) STANDARD DRAWING

STD. CSA A257.2 REV 2014 DOC PA0XXXX4

TITLE

REINFORCED CONCRETE PIPE
300 - 975mm DIAMETER
JOINT AND STENCILING DETAILS

4	CSA A257.2-2014	SW	5APR16
3	CCP TITLE BLOCK	SW	16SEP14
2	ADD ENG STAMP	SW	19OCT11
REV.	DESCRIPTION	ENG.	DATE

DRAWN BY SW	CHECKED BY CW	DATE 4JAN11	FILE Pipe	PAGE 2 OF 2
----------------	------------------	----------------	--------------	----------------