

STENCIL	EMBOSS
CCP-GUELPH OPSS1821 (SIZE) RADIUS LEFT (D.E.C) TYPE HSe (DATE OF MFG)	CC OPSS 1821 (D.E.C) (DATE OF MFG)

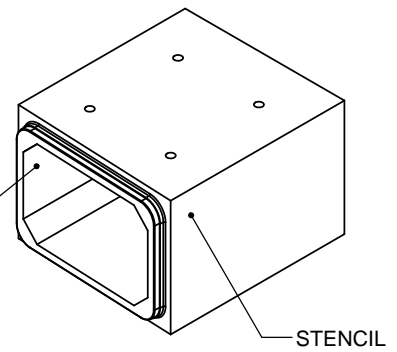

ISOMETRIC VIEW
(AS INSTALLED)

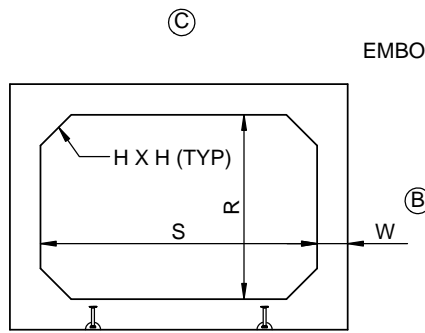

PLAN VIEW

"D" TO BE SPECIFIED

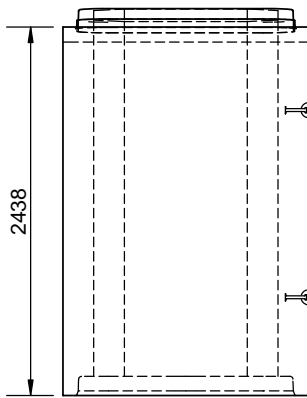

D

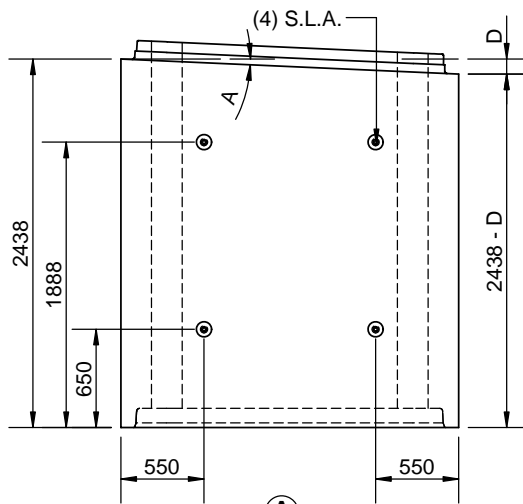

A

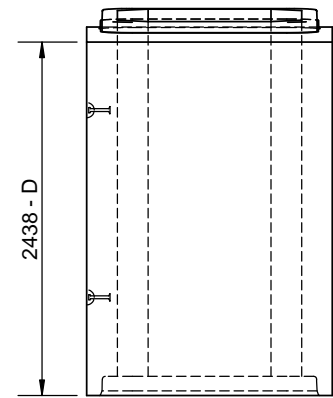

B

PRODUCT VARIABLES										
VARIABLE DIMENSIONS						S.L.A.	MASS (kg)	D.E.C		
S	R	W	H	D (MAX)	A (MAX)					
1800	900	200	200	87	2°20'	4T x 5-1/2"	7960	0.6-5.5m		
1829	1219	203	203	97	2°30'	4T x 5-1/2"	8953	0.6-5.5m		
2438	1219	203	203	116	2°20'	4T x 5-1/2"	10444	0.6-3.6m		
2438	1524	203	203	116	2°20'	4T x 5-1/2"	11191	0.6-3.6m		
2438	1829	203	203	124	2°30'	4T x 5-1/2"	11938	0.6-3.6m		
3048	1524	254	254	120	1°55'	8T x 7-1/8"	16347	0.6-3.6m		
3048	1829	254	254	149	2°25'	8T x 7-1/8"	17282	0.6-3.6m		
3048	2134	254	254	144	2°20'	8T x 7-1/8"	17750	0.6-3.6m		
3048	2438	254	254	144	2°20'	8T x 7-1/8"	19148	0.6-3.6m		

ENGINEER STAMP (IF REQUIRED)

ALL DIMENSIONS ARE IN mm
DRAWINGS ARE NOT TO SCALE
ALL VIEWS AS Poured UNLESS SPECIFIED
WWF SHEETS TO ASTM A1064
WWF Fy = 485MPa (Deformed) 450MPa (Smooth)
DROP ANGLE VALIDATED BY HP
*DROP ANGLE NOT VALIDATED BY HP

MIN. CONC STRENGTH 35 MPa
CLEAR COVER = 40 mm ± 5 mm
TOLERANCES TO OPSS 1821
CEMENT TYPE HSe
FOR JOINT DETAIL,
SEE DWG BXXXXX1-JOINT

CON CAST PIPE (CCP) STANDARD DRAWING

STD. OPSS 1821	NOV 2015	DOC ID BRXXXX1L
----------------	----------	-----------------

TITLE
**RADIUS BOX CULVERT
LEFT
2438 LAY LENGTH
(DRY CAST)**

3			
2			
1	MAX DROP UPDATED FOR 3048X1524	EM	15NOV16
0	INITIAL RELEASE	SW	5MAY16
REV.	DESCRIPTION	ENG.	DATE

DRAWN BY SW	CHECKED BY BA	DATE 01/MAR/11	FILE radius box UNIT - REV1.SLDDRW01
-------------	---------------	----------------	--------------------------------------