

**GENERAL NOTES:**

- (1) WALL AND SLAB THICKNESS IN THE TABLE ARE TYPICAL FOR CHBDC CL625-ONT LOADING WITH EARTH COVER BETWEEN 0 - 3.6m.
- (3) MASS IS APPROXIMATE BASED ON 2480 kg/m<sup>3</sup> DENSITY OF CONCRETE.
- (4) CIP OR PRECAST FOOTING ARE REQUIRED FOR PROPER INSTALLATION. SIZE TO BE DETERMINED BY CONSULTING ENGINEER
- (5) LIFTING DEVICES ARE DAYTON SWIFT LIFT ANCHOR OR EQUIVALENT
- (6) LONGER LAY LENGTH (L UPTO 3658) IS AVAILABLE

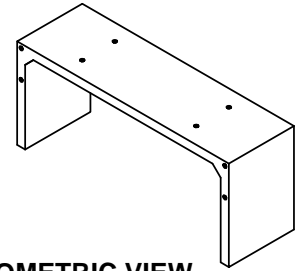

**ISOMETRIC VIEW**

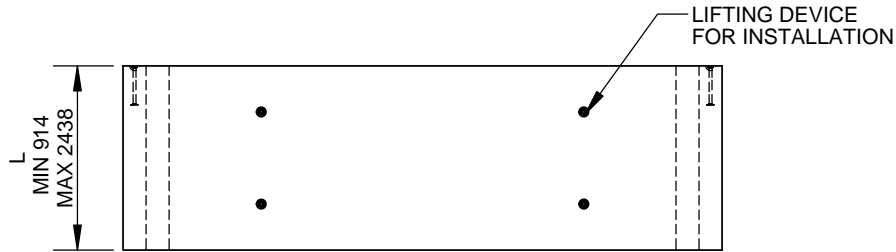

**PLAN VIEW**

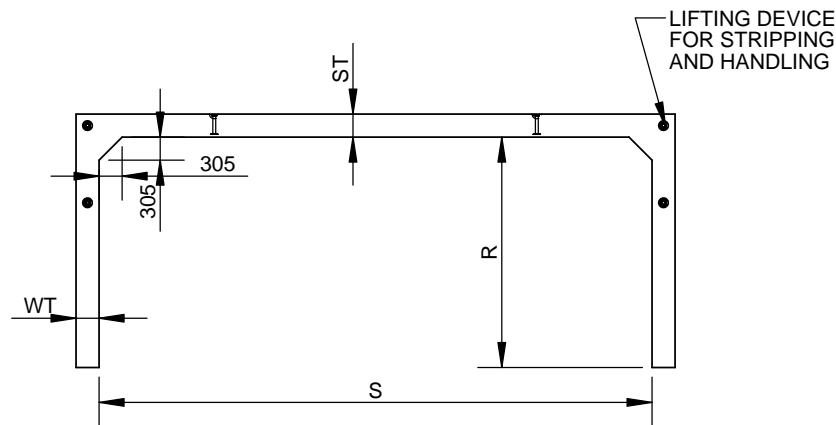

**TYPICAL SECTION VIEW**

PRODUCT VARIABLES			
WT	ST	S (RANGE)	S (FEET)
254	254	1829 - 3658	6 - 12
305	305	3048 - 6096	10 - 20
356	356	4879 - 7925	16 - 26

ALL DIMENSIONS ARE IN mm UNLESS SPECIFIED  
DRAWINGS ARE NOT TO SCALE  
FOR EQUIPMENT, SEE DWG: TS-SIZE-03

TOLERANCES TO CSA A23.4-09

**CON CAST PIPE (CCP) STANDARD DRAWING**

STD. CCP      ENG GUIDE B 10.1      PART TS-SIZE01

TITLE  
**TRI-SPAN  
SIZE GUIDE  
SMALL SPAN**

2	REVIEW NOTES	SW	7MAR14
1	INITIAL RELEASE	SW	19/OCT/2011
REV.	DESCRIPTION	ENG.	DATE

DRAWN BY SW	CHECKED BY AP	DATE 19/OCT/2011	FILE Trispan Size Guide.SLDDRW	PAGE 1 OF 4
----------------	------------------	---------------------	-----------------------------------	----------------

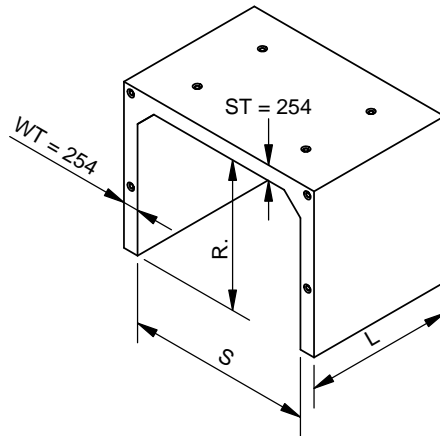

ISOMETRIC VIEW

S = 1829 (6 FEET)					
R	ST	WT	L (MAX)	MASS	
				kg/m	kg/PC
914	254	254	2.438	2855	6960
1067	254	254	2.438	3047	7428
1219	254	254	2.438	3239	7896
1372	254	254	2.438	3431	8364
1524	254	254	2.438	3623	8832
1676	254	254	2.438	3815	9300
1829	254	254	2.438	4007	9768
1981	254	254	2.438	4199	10236
2134	254	254	2.438	4391	10705
2286	254	254	2.438	4583	11173
2438	254	254	2.438	4775	11641

S = 3048 (10 FEET)					
R	ST	WT	L (MAX)	MASS	
				kg/m	kg/PC
914	254	254	2.438	3623	8832
1067	254	254	2.438	3815	9300
1219	254	254	2.438	4007	9768
1372	254	254	2.438	4199	10236
1524	254	254	2.438	4391	10705
1676	254	254	2.438	4583	11173
1829	254	254	2.438	4775	11641
1981	254	254	2.438	4967	12109
2134	254	254	2.438	5159	12577
2286	254	254	2.438	5351	13045
2438	254	254	2.438	5543	13513

S = 2438 (8 FEET)					
R	ST	WT	L (MAX)	MASS	
				kg/m	kg/PC
914	254	254	2.438	3239	7896
1067	254	254	2.438	3431	8364
1219	254	254	2.438	3623	8832
1372	254	254	2.438	3815	9300
1524	254	254	2.438	4007	9768
1676	254	254	2.438	4199	10236
1829	254	254	2.438	4391	10705
1981	254	254	2.438	4583	11173
2134	254	254	2.438	4775	11641
2286	254	254	2.438	4967	12109
2438	254	254	2.438	5159	12577

S = 3658 (12 FEET)					
R	ST	WT	L (MAX)	MASS	
				kg/m	kg/PC
914	254	254	2.438	4007	9768
1067	254	254	2.438	4199	10236
1219	254	254	2.438	4391	10705
1372	254	254	2.438	4583	11173
1524	254	254	2.438	4775	11641
1676	254	254	2.438	4967	12109
1829	254	254	2.438	5159	12577
1981	254	254	2.438	5351	13045
2134	254	254	2.438	5543	13513
2286	254	254	2.438	5735	13981
2438	254	254	2.438	5927	14449

ALL DIMENSIONS ARE IN mm UNLESS SPECIFIED  
DRAWINGS ARE NOT TO SCALE  
FOR EQUIPMENT, SEE DWG: EQ-TS03

TOLERANCES TO CSA A23.4-09

CON CAST PIPE (CCP) STANDARD DRAWING

STD. CCP	ENG GUIDE B 10.1	PART TS-SIZE01
----------	------------------	----------------

TITLE  
**TRI-SPAN  
 SIZE GUIDE  
 SMALL SPAN**  
 WALL = 254mm SLAB = 254mm

3	UPDATE MIN TRISPAN LENGTH	KE	14/JAN/16
2	UPDATE DIMENSION BASED ON FORMWORK AVAILABILITY	SW	20OCT15
1	INITIAL RELEASE	SW	7MAR14
REV.	DESCRIPTION	ENG.	DATE

DRAWN BY SW	CHECKED BY AP	DATE 19/OCT/2011	FILE Trispan Size Guide.SLDDRW	PAGE 2 OF 4
-------------	---------------	------------------	--------------------------------	-------------

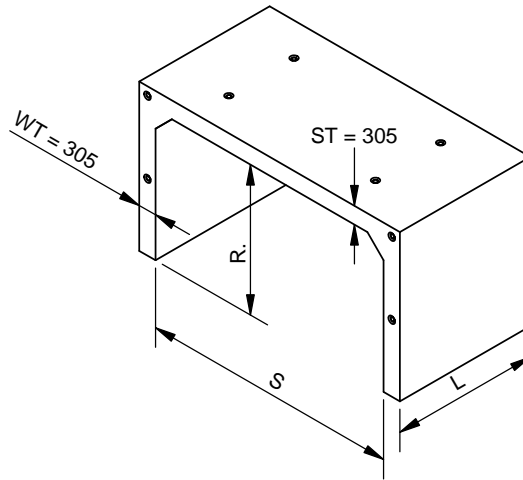

ISOMETRIC VIEW

S = 3048 (10 FEET)					
R	ST	WT	L (MAX)	MASS	
				kg/m	kg/PC
914	305	305	2.438	4381	10681
1067	305	305	2.438	4611	11243
1219	305	305	2.438	4842	11805
1372	305	305	2.438	5073	12367
1524	305	305	2.438	5303	12929
1676	305	305	2.438	5534	13491
1829	305	305	2.438	5764	14053
1981	305	305	2.438	5995	14615
2134	305	305	2.438	6225	15177
2286	305	305	2.438	6456	15739
2438	305	305	2.438	6686	16302

S = 4267 (14 FEET)					
R	ST	WT	L (MAX)	MASS	
				kg/m	kg/PC
914	305	305	2.438	5303	12929
1067	305	305	2.438	5534	13491
1219	305	305	2.438	5764	14053
1372	305	305	2.438	5995	14615
1524	305	305	2.438	6225	15177
1676	305	305	2.438	6456	15739
1829	305	305	2.438	6686	16302
1981	305	305	2.438	6917	16864
2134	305	305	2.438	7148	17426
2286	305	305	2.438	7378	17988
2438	305	305	2.438	7609	18550

S = 5486 (18 FEET)					
R	ST	WT	L (MAX)	MASS	
				kg/m	kg/PC
914	305	305	2.438	6225	15177
1067	305	305	2.438	6456	15739
1219	305	305	2.438	6686	16302
1372	305	305	2.438	6917	16864
1524	305	305	2.438	7148	17426
1676	305	305	2.438	7378	17988
1829	305	305	2.438	7609	18550
1981	305	305	2.438	7839	19112
2134	305	305	2.438	8070	19674
2286	305	305	2.438	8300	20236
2438	305	305	2.438	8531	20798

S = 3658 (12 FEET)					
R	ST	WT	L (MAX)	MASS	
				kg/m	kg/PC
914	305	305	2.438	4842	11805
1067	305	305	2.438	5073	12367
1219	305	305	2.438	5303	12929
1372	305	305	2.438	5534	13491
1524	305	305	2.438	5764	14053
1676	305	305	2.438	5995	14615
1829	305	305	2.438	6225	15177
1981	305	305	2.438	6456	15739
2134	305	305	2.438	6686	16302
2286	305	305	2.438	6917	16864
2438	305	305	2.438	7148	17426

S = 4877 (16 FEET)					
R	ST	WT	L (MAX)	MASS	
				kg/m	kg/PC
914	305	305	2.438	5764	14053
1067	305	305	2.438	5995	14615
1219	305	305	2.438	6225	15177
1372	305	305	2.438	6456	15739
1524	305	305	2.438	6686	16302
1676	305	305	2.438	6917	16864
1829	305	305	2.438	7148	17426
1981	305	305	2.438	7378	17988
2134	305	305	2.438	7609	18550
2286	305	305	2.438	7839	19112
2438	305	305	2.438	8070	19674

S = 6096 (20 FEET)					
R	ST	WT	L (MAX)	MASS	
				kg/m	kg/PC
914	305	305	2.438	6686	16302
1067	305	305	2.438	6917	16864
1219	305	305	2.438	7148	17426
1372	305	305	2.438	7378	17988
1524	305	305	2.438	7609	18550
1676	305	305	2.438	7839	19112
1829	305	305	2.438	8070	19674
1981	305	305	2.438	8300	20236
2134	305	305	2.438	8531	20798
2286	305	305	2.438	8761	21360
2438	305	305	2.438	8992	21922

ALL DIMENSIONS ARE IN mm UNLESS SPECIFIED  
DRAWINGS ARE NOT TO SCALE  
FOR EQUIPMENT, SEE DWG: EQ-TS03

TOLERANCES TO CSA A23.4-09

CON CAST PIPE (CCP) STANDARD DRAWING

STD. CCP ENG GUIDE B 10.1 PART TS-SIZE01

TITLE  
TRI-SPAN  
SIZE GUIDE  
SMALL SPAN  
WALL = 305mm SLAB = 305mm

3	UPDATE MIN TRISPAN LENGTH	KE	14/JAN/16
2	UPDATE DIMENSION BASED ON FORMWORK AVAILABILITY	SW	20OCT15
1	INITIAL RELEASE	SW	7MAR14
REV.	DESCRIPTION	ENG.	DATE

DRAWN BY SW	CHECKED BY AP	DATE 19/OCT/2011	FILE Trispan Size Guide.SLDDRW	PAGE 3 OF 4
----------------	------------------	---------------------	-----------------------------------	----------------

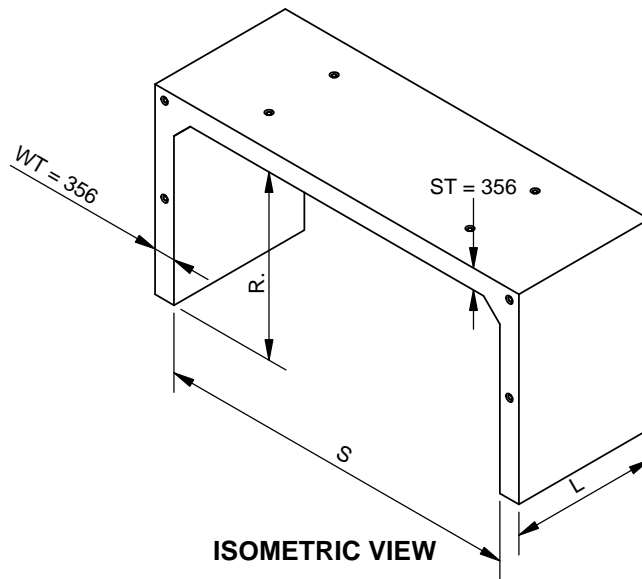

S = 4877 (16 FEET)					
R	ST	WT	L (MAX)	MASS	
				kg/m	kg/PC
914	356	356	2.438	6780	16529
1067	356	356	2.438	7049	17185
1219	356	356	2.438	7318	17841
1372	356	356	2.438	7587	18497
1524	356	356	2.438	7856	19153
1676	356	356	2.438	8125	19809
1829	356	356	2.438	8394	20465
1981	356	356	2.438	8663	21121
2134	356	356	2.438	8932	21777
2286	356	356	2.438	9201	22433
2438	356	356	2.438	9471	23089

S = 6096 (20 FEET)					
R	ST	WT	L (MAX)	MASS	
				kg/m	kg/PC
914	356	356	2.438	7856	19153
1067	356	356	2.438	8125	19809
1219	356	356	2.438	8394	20465
1372	356	356	2.438	8663	21121
1524	356	356	2.438	8932	21777
1676	356	356	2.438	9201	22433
1829	356	356	2.438	9471	23089
1981	356	356	2.438	9740	23745
2134	356	356	2.438	10009	24401
2286	356	356	2.438	10278	25057
2438	356	356	2.438	10547	25714

S = 7315 (24 FEET)					
R	ST	WT	L (MAX)	MASS	
				kg/m	kg/PC
914	356	356	2.438	8932	21777
1067	356	356	2.438	9201	22433
1219	356	356	2.438	9471	23089
1372	356	356	2.438	9740	23745
1524	356	356	2.438	10009	24401
1676	356	356	2.438	10278	25057
1829	356	356	2.438	10547	25714
1981	356	356	2.438	10816	26370
2134	356	356	2.438	11085	27026
2286	356	356	2.438	11354	27682
2438	356	356	2.438	11623	28338

S = 5486 (18 FEET)					
R	ST	WT	L (MAX)	MASS	
				kg/m	kg/PC
914	356	356	2.438	7318	17841
1067	356	356	2.438	7587	18497
1219	356	356	2.438	7856	19153
1372	356	356	2.438	8125	19809
1524	356	356	2.438	8394	20465
1676	356	356	2.438	8663	21121
1829	356	356	2.438	8932	21777
1981	356	356	2.438	9201	22433
2134	356	356	2.438	9471	23089
2286	356	356	2.438	9740	23745
2438	356	356	2.438	10009	24401

S = 6706 (22 FEET)					
R	ST	WT	L (MAX)	MASS	
				kg/m	kg/PC
914	356	356	2.438	8394	20465
1067	356	356	2.438	8663	21121
1219	356	356	2.438	8932	21777
1372	356	356	2.438	9201	22433
1524	356	356	2.438	9471	23089
1676	356	356	2.438	9740	23745
1829	356	356	2.438	10009	24401
1981	356	356	2.438	10278	25057
2134	356	356	2.438	10547	25714
2286	356	356	2.438	10816	26370
2438	356	356	2.438	11085	27026

S = 7925 (26 FEET)					
R	ST	WT	L (MAX)	MASS	
				kg/m	kg/PC
914	356	356	2.438	9471	23089
1067	356	356	2.438	9740	23745
1219	356	356	2.438	10009	24401
1372	356	356	2.438	10278	25057
1524	356	356	2.438	10547	25714
1676	356	356	2.438	10816	26370
1829	356	356	2.438	11085	27026
1981	356	356	2.438	11354	27682
2134	356	356	2.438	11623	28338
2286	356	356	2.438	11892	28994
2438	356	356	2.438	12162	29650

ALL DIMENSIONS ARE IN mm UNLESS SPECIFIED  
DRAWINGS ARE NOT TO SCALE  
FOR EQUIPMENT, SEE DWG: EQ-TS03

TOLERANCES TO CSA A23.4-09

CON CAST PIPE (CCP) STANDARD DRAWING

STD. CCP	ENG GUIDE B 10.1	PART TS-SIZE01
----------	------------------	----------------

TITLE  
**TRI-SPAN  
 SIZE GUIDE  
 SMALL SPAN**  
**WALL = 356mm SLAB = 356mm**

3	UPDATE MIN TRISPAN LENGTH	KE	14/JAN/16
2	UPDATE DIMENSION BASED ON FORMWORK AVAILABILITY	SW	20OCT15
1	INITIAL RELEASE	SW	7MAR14
REV.	DESCRIPTION	ENG.	DATE

DRAWN BY SW	CHECKED BY AP	DATE 19/OCT/2011	FILE Trispan Size Guide.SLDDRW	PAGE 4 OF 4
-------------	---------------	------------------	--------------------------------	-------------