

STENCIL	EMBOSS
CCP-GUELPH OPSS1821 (SIZE) STD (D.E.C) TYPE HSe (DATE OF MFG)	CC OPSS 1821 (D.E.C) (DATE OF MFG)

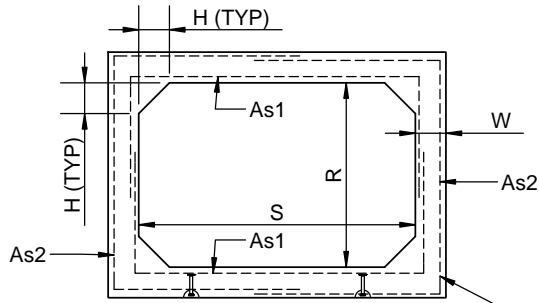

TYPICAL SECTION A

SEE REINFORCING DETAIL  
WIP3BAXXXX1

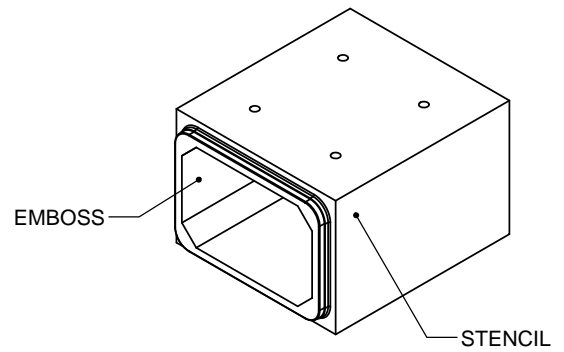

ISOMETRIC VIEW  
(AS INSTALLED)

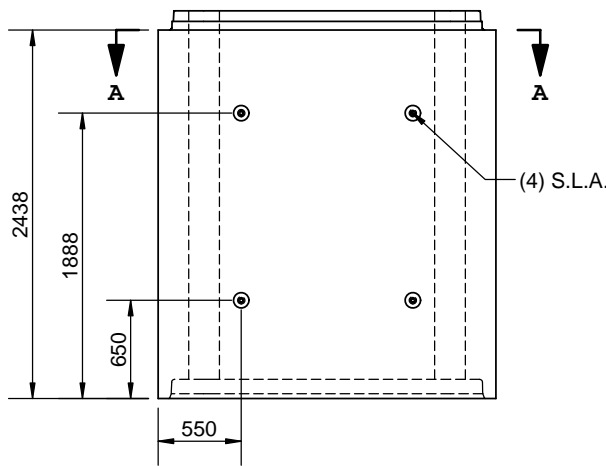

LEFT  
(RIGHT MIRRORED)

PRODUCT VARIABLES							
PART ID	VARIABLE DIMENSIONS				S.L.A.	MASS (kg)	D.E.C
	S	R	W	H			
BA18091	1800	900	200	200	4T x 5-1/2"	7960	0.6-5.5m
BA18121	1829	1219	203	203	4T x 5-1/2"	8953	0.6-5.5m
BA24121	2438	1219	203	203	4T x 5-1/2"	10444	0.6-3.6m
BA24151	2438	1524	203	203	4T x 5-1/2"	11191	0.6-3.6m
BA24181	2438	1829	203	203	4T x 5-1/2"	11938	0.6-3.6m
BA30151	3048	1524	254	254	8T x 7-1/8"	16347	0.6-3.6m
BA30181	3048	1829	254	254	8T x 7-1/8"	17282	0.6-3.6m
BA30211	3048	2134	254	254	8T x 7-1/8"	17750	0.6-3.6m
BA30241	3048	2438	254	254	8T x 7-1/8"	19148	0.6-3.6m

ENGINEER STAMP (IF REQUIRED)

ALL DIMENSIONS ARE IN mm  
DRAWINGS ARE NOT TO SCALE  
ALL VIEWS AS POURED UNLESS SPECIFIED  
WWF SHEETS TO ASTM A1064  
WWF Fy = 485MPa (Deformed) 450MPa (Smooth)

MIN. CONC STRENGTH 35 MPa  
CLEAR COVER = 40 mm ± 5 mm  
TOLERANCES TO OPSS 1821  
CEMENT TYPE HSe  
FOR JOINT DETAIL,  
SEE DWG BXXXXX1-JOINT

CON CAST PIPE (CCP) STANDARD DRAWING

STD. OPSS 1821 NOV 2015 PART BAXXXX1

TITLE  
STANDARD BOX CULVERT  
2438 LAY LENGTH  
(DRY CAST)

5	UPDATE AS PER OPSS1821	SW	2FEB16
4	CHANGE SLA SIZE FOR 3000 SPAN SERIES	SM	10SEP15
3	ADD 3021 SIZE INFO	KE	27/JUL/15
2	AS INSTALL ISO VIEW; MOVE WC TO NEW DWG	CW	09/JAN/12
REV.	DESCRIPTION	ENG.	DATE

DRAWN BY CW	CHECKED BY SW	DATE 01/MAR/11	FILE BOX UNIT.SLDDRW	PAGE 1 OF 1
----------------	------------------	-------------------	-------------------------	----------------